

1-1-1967

Preliminary design of a positron storage device

Ricardo Jose Cocito
Iowa State University

Follow this and additional works at: <https://lib.dr.iastate.edu/rtd>

 Part of the [Engineering Commons](#)

Recommended Citation

Cocito, Ricardo Jose, "Preliminary design of a positron storage device" (1967). *Retrospective Theses and Dissertations*. 18053.
<https://lib.dr.iastate.edu/rtd/18053>

This Thesis is brought to you for free and open access by the Iowa State University Capstones, Theses and Dissertations at Iowa State University Digital Repository. It has been accepted for inclusion in Retrospective Theses and Dissertations by an authorized administrator of Iowa State University Digital Repository. For more information, please contact digirep@iastate.edu.

PRELIMINARY DESIGN
OF A
POSITRON STORAGE DEVICE

by

Ricardo Jose Cocito

A Thesis Submitted to the
Graduate Faculty in Partial Fulfillment of
The Requirements for the Degree of
MASTER OF SCIENCE

Major Subject: Nuclear Engineering

Signatures have been redacted for privacy

Iowa State University
Of Science and Technology
Ames, Iowa

1967

TABLE OF CONTENTS

	Page
I. INTRODUCTION	1
A. Purpose of the Study	1
B. Result of Literature Survey	1
II. OUTLINE OF THEORY	6
III. OTHER THEORETICAL ASPECTS AND PRELIMINARY DESIGN	8
A. The Radioactive Source of Positrons	8
B. The Shape of the Source	9
C. The Shape and Size of the Container	12
D. Positron Annihilation and Steady State	16
E. Collision Phenomena	17
F. Electric Field	19
G. Pressure	20
H. Drift Velocity	22
I. Radiation Losses	24
IV. DISCUSSION AND CONCLUSIONS	27
A. Discussion	27
B. Recommendations for Further Study	30
V. BIBLIOGRAPHY	31

I. INTRODUCTION

A. Purpose of the Study

It is the purpose of this thesis to investigate, from a theoretical point of view, the possibility of constructing a positron storage facility, where the positron's source is a radioactive element.

B. Result of Literature Survey

According to Gerard K. O'Neill (1), during the past two years a new method of carrying out experiments in high-energy physics has achieved its first successes. It consists of inducing sub-atomic particles to collide with each other head on, in contrast to conventional high-energy experiments in which accelerated particles collide with particles that are at rest. Since it is very difficult to arrange for particles in two beams to collide, the rewards must be high enough to justify the effort. The rewards are in terms of energy.

All collision experiments in high-energy physics until two years ago involved stationary targets. That was not a serious disadvantage when particles speeds were relatively low, but accelerators built in the past few years can accelerate particles to speeds quite close to the speed of light. At such speeds the formulas of the special theory of relativity must be used. The relativistic formulas show that for stationary targets the collision energy is an increasingly

smaller fraction of the input energy as the speed of the incident particle approaches the speed of light. Goujou and Sittel (2) tell us that when an accelerated proton with an energy of 28 Gev, such as attained in CERN synchrotron, collides with particles that are at rest, the new group of originated particles in the event is ejected from the target with a great velocity. The result is that a great part of the initial energy of the proton remains in the form of kinetic energy, that is, a loss of energy for the experiment. The calculations show that the useful energy in this case is only of 7 Gev. For the largest accelerators now being planned, about 300 Gev, the amount of lost energy will be larger than nine tenth.

On the other hand, if two protons are directed at each other, so that there will be a head on collision, both protons will be stopped, and therefore there will be no energy lost as kinetic energy. If the two protons have an energy of 28 Gev each, like those of CERN synchrotron, the sum of their energies will be 56 Gev. To obtain such a useful energy from protons colliding with particles at rest it would be necessary to have an accelerator of 1,700 Gev, an enormous machine of several miles of diameter and whose cost is at present considered as prohibitive.

It is clear from the low conversion of input energy to collision energy in conventional accelerators that there is good reason to press for the development of colliding beams

devices. To make the idea practical one must first solve the problem of achieving a reasonable rate of interaction between particles in the two beams. The density of particles emitted in one cycle of an accelerator is sufficient to achieve a reasonable amount of collisions in a fixed target, because the matter is very dense in it. In the second case the probability of collision among the particles of the two colliding particle pulses of the same density as before would be very small. To overcome this, the particles may be stored in some device, so that the particles can circulate and be increased in density before they collide. The way to attain this goal consists of collecting the particles from many acceleration cycles and storing them in a ringlike device.

Later in 1956 the same Gerard K. O'Neill began to design an experiment that would involve colliding electron beams in storage rings. In year 1959 construction was begun on a pair of storage rings to be located at the Stanford one-Gev linear electron accelerator.

Another research group contributed much in the understanding of storage rings and achieved some specific goals. This group, consisting of Italian physicists decided early in 1960 to make a small storage ring for both negative and positive electrons (positrons) of .25 Gev. They call their machine "Ada", for "Anelli d'accumulazione (accumulation rings). There was no intention of using it for a real experiment in high-energy physics; rather it was for the study of

storage rings themselves. By late 1961 Ada was equipped with an ultrahigh-vacuum chamber, and in it stored electrons were made to circulate for several hours.

Later last year an electron-electron storage ring at Novosibirsk began producing data at .04 Gev.

The principal reaction for rings storing electrons (e^-) and positrons (e^+) will be the production of particle-anti-particle pairs, according to the reaction $e^- + e^+ \rightarrow A + \bar{A}$. A can be any particle and \bar{A} its antiparticle, as long as the energy of the beam particle exceeds the rest energy of A. Nearly all particles that have a life time longer than about 10^{-20} second have rest energies less than 1.3 Gev, and so many shortlived particles. The new 1.5 Gev storage ring facility at Frascati, called "Adone" (for big "Ada") (3) will therefore be able to open up many new reactions for study.

In 1956, at the beginning of the present interest in colliding-beam devices, the primary goal was proton-proton storage rings. In the intervening decade it was recognized that the initial goal was much harder to reach than that of building electron-electron storage rings.

After 1960, when the theoretical situation became fairly clear, there were several attempts to initiate construction projects for proton rings. Of these the most consistent, well organized and systematic was carried out at CERN in Geneva. In 1962 they adopted a concentric design and conducted a study program on the design and experiments. In 1965 the CERN

nations gave their final approval to the construction of the CERN intersecting storage rings (I.S.R.). After a year of detailed design the construction of the rings was begun, and their completion is expected about 1971.

All of these devices however are coupled with accelerators. This led to the idea of using a radioactive source for positrons in a storage device. Such a device would be somewhat different in design from the conventional storage rings and its purpose would not be to form a collimated beam, but it would be to accumulate a quantity of positrons which could then be used for various purposes. The preliminary design for such a device is considered in the following chapters.

II. OUTLINE OF THEORY

When positrons are emitted by a source their concentration in the vicinity of the source rapidly dwindles with distance through the effect of two mechanisms:

a. The geometric divergence as the positrons are radiated away from the source usually at high velocities (often of the same order of magnitude as that of light).

b. The attenuation through annihilation by electrons in the vicinity of the source.

Concerning the first effect, then if the flux is designated as being ϕ_0 at the source it will be diminished by the inverse square law as one proceeds away from the source to give, at a distance r a flux

$$\phi_1 = \phi_0 \frac{1}{4\pi r^2} \quad 1$$

As for the second effect, the attenuation of the flux will be given by the well known relation

$$\phi_1 = \phi_0 e^{-N\sigma r} \quad 2$$

where:

N is the electron concentration

σ is the cross section for electron positron annihilation.

The actual flux at a distance r will then be:

$$\phi = \phi_0 \frac{e^{-N\sigma r}}{4\pi r^2} \quad 3$$

Since the flux is equal to the product of the positron concentration, ρ , and the positron velocity, v , then the concentration at r will be

$$\rho = \phi_0 \frac{e^{-Ner}}{4\pi vr^2}$$

4

For high positron velocities and electron concentrations in the vicinity of the source the positron density falls off quite rapidly due to the two above mentioned effects.

The way to overcome these two effects is first of all to provide a magnetic field that will deflect the positrons back to the vicinity of the source, and second to remove the electrons from that vicinity. What this boils down to is an evacuated magnetic bottle.

The preliminary design of such a device will be considered in the next chapters along with the other aspects of the necessary theory. These are:

- a. Selection of positron source
- b. Source shape
- c. The size and shape of the magnetic bottle
- d. The annihilation rate of positrons
- e. Positron collisions
- f. The electric field within the bottle
- g. The pressure exerted by the magnetic and electric field on the positrons
- h. The drift of the positrons
- i. Radiation losses

III. OTHER THEORETICAL ASPECTS AND PRELIMINARY DESIGN

A. The Radioactive Source of Positrons

After inspecting the radioactive characteristics of the elements we decided to take the Zn^{65} for our source, which may be formed by irradiating Zn^{64} with neutrons:

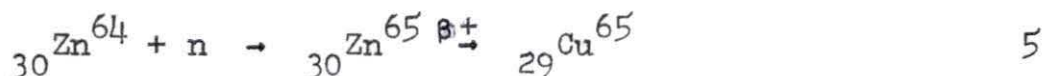

The characteristics of the nuclide Zn^{65} are the following taken from Friedlander, Kennedy and Miller (4).

Half-life: 245 days

Decay modes: EC; γ 1.11 Mev; β^+ 0.33 Mev; (2.5%)

and the characteristics of Zn^{64} :

Abundance: 48,89%

Thermal neutron cross-section: $\sigma_n = 0.47$ barn

Taking a little speck of Zn^{64} , e.g., 2 mg, the number of atoms of Zn^{64} is

$$N^{64} = \frac{0.002 \times 48.89}{64 \times 100} \times 6.03 \times 10^{23} = 9.23 \times 10^{18} \quad 6$$

The rate of formation of Zn^{65} by irradiation of the thin target of 2 mg with thermal neutrons will be

$$P = \phi \sigma_n N^{64} \quad 7$$

and assuming a typical reactor flux, $\phi = 10^{13}$ n/cm²sec:

$$P = 10^{13} \times 0.47 \times 10^{-24} \times 9.23 \times 10^{18} = 4.35 \times 10^7 \text{ sec}^{-1} \quad 8$$

Assuming the rate P is maintained constant throughout the irradiation period, the number N^{65} of Zn^{65} after irradiation time t is

$$N^{65} = \frac{P}{\lambda} (1 - e^{-\lambda t}) \quad 9$$

and in terms of activity and half-life this is

$$A^{65} = P(1 - e^{-.693xt/245 \text{ d}}) \quad 10$$

To reach a reasonable activity we set $t = 245$ days, so that

$$\begin{aligned} A &= 4.35 \times 10^7 (1 - e^{-.693}) = 2.18 \times 10^7 \text{ sec}^{-1} \quad 11 \\ &= 0.588 \times 10^{-3} \text{ c} \end{aligned}$$

$$A = 2.18 \times 10^7 \times \frac{1 \text{ c}}{3.7 \times 10^{10} \text{ sec}^{-1}} \quad 12$$

$$A = 0.588 \text{ mc}$$

The production of positrons according to the irradiation percentage of β^+ (2.5%) (5) is

$$A_{\beta^+} = 0.015 \text{ mc} \quad 13$$

The effect of removal of Zn^{65} by reaction with neutrons can be ignored, because of its extremely small cross-section.

B. The Shape of the Source

To choose the most suitable shape of the source we must allow for the absorption of positrons in the same source.

Beta-ray ranges expressed in mgcm^{-2} are nearly independent of the absorber material and from Friedlander (4) we get for $E = 0.33$ Mev a range of 90 mgcm^{-2} . This range is equivalent to

$$\frac{90 \text{ mgcm}^{-2}}{7,133 \text{ mgcm}^{-2}/\text{cm}} = 0.0126 \text{ cm} = 0.126 \text{ mm} \quad 14$$

the density of Zn being 7.133 grcm^{-3} .

From Price (6) we learn that a large portion of absorption curve for a specific beta particle source can be represented by an exponential curve of the form

$$\text{Relative intensity} = e^{-\mu d} \quad 15$$

where μ is the mass absorption coefficient in $\text{cm}^2\text{gr}^{-1}$ and d is the absorber thickness in grcm^{-2} .

According to Evans (7) an empirical relation which gives approximate values for the mass absorption coefficient is

$$\mu = \frac{17}{E_m^{1.14}} \quad 16$$

where E_m is the maximum energy of the beta emitter in Mev. The expression fits, reasonably well at least, the range $.1 < E_m < 4$ Mev, as it is in our case. Consequently

$$\mu = \frac{17}{0.33^{1.14}} = \frac{17}{0.283} = 60.1 \text{ cm}^2\text{gr}^{-1} \quad 17$$

Substituting in 15

$$\frac{1}{2} = e^{-60.1 \times d_{\frac{1}{2}}} \quad 18$$

$$d_{\frac{1}{2}} = \frac{\ln 2}{60.1} = 0.0115 \text{ gr cm}^{-2} \quad 19$$

$$d_{\frac{1}{2}} = \frac{0.0115 \text{ gr cm}^{-2}}{7.133 \text{ gr cm}^{-3}} = 0.00162 \text{ cm} = 0.0162 \text{ mm} \quad 20$$

This half thickness is in agreement with the statement of Friedlander, that the ratio of range to initial half thickness is generally between 5 and 10.

All things considered, the tiny mass of 2 mg, the small half thickness and the difficulty of making the sample, we decided to choose the shape of a round disc of thickness equal to the half thickness and whose radius R must be

$$\pi R^2 \times 0.0162 \times 7.133 = 2$$

$$R = \sqrt{\frac{2}{7.133 \times 0.0162 \times \pi}} = 2.34 \text{ mm} \quad 21$$

Considering the center of mass of the disc one can see that about two thirds of the positrons will travel less than the half thickness inside the sample. Consequently it seems reasonable to assume that the rate of positrons escaping the disc will correspond to about two thirds of the entire irradiation rate, that is

$$A = 0.01 \text{ mc} \quad 22$$

To check this estimate one can calculate the relative

average radiation going out from the central part of the disc, noticing that the edge of the disc does not affect it substantially,

$$I_{\text{avg}} = \frac{\int_0^{\pi/2} I d\alpha}{\pi/2}$$

23

where $I = e^{-\mu d} = e^{-\mu \delta \sec \alpha}$, and $\delta = \frac{1}{2}(d_1)$.

The integral was solved graphically and the result was $I_{\text{avg}} = 0.513$.

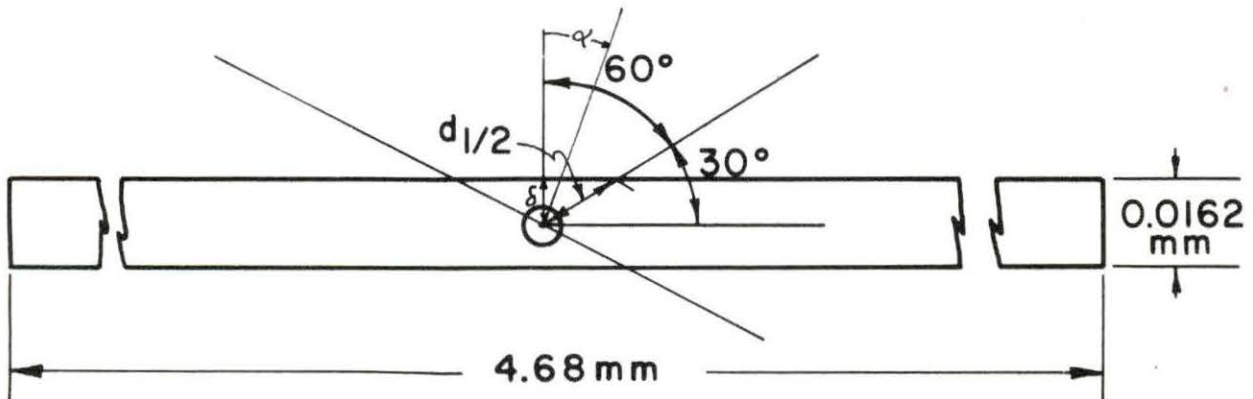

Figure 1. The disc source
(edgewise projection)

Since the irradiation going out from the central part of the disc is the most likely to be absorbed, the former estimate of $2/3$ seems to be reasonable.

C. The Shape and Size of the Container

In a magnetic field charged particles gyrate about the lines of force, the positive particles in one direction and

the negative ones in the opposite direction. Hence, apart from the effect of collisions, in a uniform magnetic field the positrons remain tied to the field lines. Although they can move freely along (or parallel) to these lines, in either direction, they can not cross the lines if there are no collisions among the particles. Hence, if the positrons can in some manner be prevented from escaping at the end of the containing vessel, e.g., by means of an endless tube of toroidal form, the use of a magnetic field of this shape appears to offer promise for confinement of the positrons.

In order that the number of positrons reaching the walls will be relatively small, the size of the circular cross-section generating the torus must be determined by the radius of gyration, which is a function of the velocity of the positrons and the magnetic field. From the special Theory of Relativity we know that

$$\frac{T}{m_0 c^2} + 1 = \frac{1}{\sqrt{1 - \beta^2}}, \quad \beta = \frac{v}{c} \quad 24$$

where

T is the kinetic energy of the particle

m_0 is its rest mass

c is the velocity of the light

v is the velocity of the particle.

Since the upper energy limit of our positrons is 0.33 Mev

the most probable energy will be equal to 0.11 Mev. The correspondent average velocity is to be calculated substituting into 24

$$\frac{1}{\sqrt{1 - \beta^2}} = \frac{0.11 \text{ Mev}}{0.511 \text{ Mev}} + 1 = 0.216 + 1 = 1.216 \quad 25$$

$$\beta = \sqrt{1 - \left(\frac{1}{1.216}\right)^2} = \sqrt{1 - 0.676} = \sqrt{0.324} = 0.568 \quad 26$$

From this figure we learn that the relativistic corrections are not important enough to be considered in this preliminary design.

The average velocity

$$\bar{v} = 0.568 \times 3 \times 10^{10} \text{ cmsec}^{-1} = 1.71 \times 10^{10} \text{ cm/sec} \quad 27$$

The average radius of gyration will be:

$$\begin{aligned} \bar{r}_g &= \frac{mv_{\perp}c}{e} = \frac{9.11 \times 10^{-28} \times 1.71 \times 10^{10} \times 3 \times 10^{10}}{4.80 \times 10^{-10}} = \\ &= 9.72 \times 10^2 \text{ gauss-cm} \end{aligned} \quad 28$$

For $B = 1,000$ gauss, $\bar{r}_g = 0.972 \text{ cm} \sim 1 \text{ cm}$

$B = 10,000$ gauss, $\bar{r}_g = 0.0972 \text{ cm} \sim 0.1 \text{ cm}$

For positrons whose perpendicular component is less than v the radius of gyration will be smaller. And for the positrons in the upper limit of the spectrum the radius of gyration reaches to $1.39 \bar{r}_g$.

As a first approximation we choose a magnetic field of 1,000 gauss, and consequently

$$\bar{r}_g = 1 \text{ cm}$$

29

With this radius of gyration the positrons will have a smaller probability of colliding with the tiny sample while they are circulating along the lines of force, than when a stronger magnetic field is used.

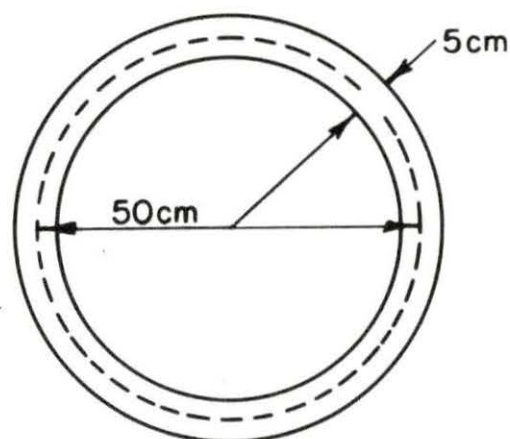

Figure 2. Dimensions of the torus

Judging from the size of the radius of gyration a suitable size of the circular cross-section generating the torus may be a 5 cm-diameter circle. The major radius of the torus should then not be less than 25 cm in order to give a fairly homogeneous magnetic field within the torus. Therefore the torus will have the following characteristics:

Radius of the generating circle $b = 2.5 \text{ cm}$

Radius of the torus $c = 25 \text{ cm}$

$$\text{Volume } V = 2\pi c x \pi b^2 = 2\pi^2 x 25 x (2.5)^2 = 3,080 \text{ cm}^3$$

$$\text{Surface } S = 2\pi c x 2\pi b = 4\pi^2 x 25 x 2.5 = 2,470 \text{ cm}^2$$

D. Positron Annihilation and Steady State

To minimize the likely annihilation of positrons in their encounter with electrons, the torus should be evacuated as highly as possible, after it has been filled with hydrogen whose atoms contain only one electron.

The cross-section of the annihilation process, averaged over the two possible mutual directions of the spin, is given by Segre (9) as

$$\bar{\sigma} = \pi r_0^2 c/v \quad \text{with } r_0 = \frac{e^2}{mc^2} = 2.82 \times 10^{-13} \text{ cm} \quad 30$$

Substituting in 30

$$\begin{aligned} \bar{\sigma} &= \pi (2.82 \times 10^{-13} \text{ cm})^2 \frac{3 \times 10^{10} \text{ cm/sec}}{1.71 \times 10^{10} \text{ cm/sec}} = 43.8 \times 10^{-26} = \\ &= 0.438 \times 10^{-24} = 0.438 \text{ barns} \end{aligned} \quad 31$$

Assuming a vacuum of 10^{-12} at the density of the electrons according to the ideal gas equation will be

$$\frac{P_0 V_0}{T_0} = \frac{p_1 V_1}{T_1}, \quad V_1 = \frac{p_0 V_0}{T_0} \times \frac{T_1}{p_1}$$

$$V_1 = \frac{1 \text{ at} \times 22,431 \text{ cm}^3}{273.16^\circ \text{K}} \times \frac{293.16^\circ \text{K}}{10^{-12} \text{ at}} = 2.41 \times 10^{16} \text{ cm}^3 \quad 32$$

$$\rho_{e^-} = \frac{2 \times 0.603 \times 10^{24}}{2.41 \times 10^{16} \text{ cm}^3} = 5.01 \times 10^7 \text{ e}^-/\text{cm}^3 \quad 33$$

If we initially assume that the magnetic field is strong enough to render leakage of positrons by diffusion across the magnetic field negligible, then the cloud of positrons will increase up to a point at which the rate of emission will be equal to the rate of the annihilation in the whole torus. At this point the steady state will be reached, and the average flux $\bar{\phi}$ of positrons will satisfy the equation

$$V\rho_e - \bar{v}\bar{\phi} = 0.01 \text{ mc} = 3.7 \times 10^5 / \text{sec} \quad 34$$

$$\begin{aligned} \bar{\phi} &= \frac{3.7 \times 10^5 / \text{sec}}{3,080 \text{ cm}^3 \times 5.01 \times 10^7 \text{ e}^- / \text{cm}^3 \times 0.438 \times 10^{-24}} = \\ &= 5.47 \times 10^{18} \text{ } \beta^+ / \text{cm}^2 \text{ sec} \quad 35 \end{aligned}$$

The corresponding density of positrons ρ_{β^+} will satisfy the relationship $\bar{\phi} = \rho_{\beta^+} \bar{v}$, so that:

$$\rho_{\beta^+} = \frac{\bar{\phi}}{\bar{v}} = \frac{5.47 \times 10^{18} / \text{cm}^2 \text{ sec}}{1.71 \times 10^{10} \text{ cm/sec}} = 3.20 \times 10^8 \text{ } \beta^+ / \text{cm}^3 \quad 36$$

E. Collision Phenomena

In the preceding discussion it has been supposed that the positrons move throughout the torus filling the whole space within it, before attaining the steady state or equilibrium between the annihilation and the production rate. This assumption may be checked considering that the cross-section for collision phenomena is much larger than that for annihilation. As a matter of fact according to Glasstone and

Lovberg (8) we have to consider two kind of collision phenomena between charged particles, namely the short-range and the long-range interaction.

For charged particles of only one kind, like in our case, the short-range collision cross-section is given by

$$\sigma_c = \frac{6.4 \times 10^4}{W^2} \text{ barns}$$

where W is the relative kinetic energy in kev. Upon substitution we get

$$\sigma_c = \frac{6.4 \times 10^4}{(110)^2} = 5.28 \text{ barns} \quad 37$$

and the long-range collision cross-section is given by

$$\sigma_d = \frac{2.6 \times 10^6}{W^2} = \frac{2.6 \times 10^6}{110^2} = 215 \text{ barns} \quad 38$$

As we can see, the Coulomb scattering will be far more probable than the annihilation process.

From another point of view, the collisions among the charged particles are not so important so far as the collision mean free path is long compared with the dimensions of the confining field, so that the single-particle picture of a cloud of charged particles is valid. That is our case. In effect, the m.f.p.

$$\lambda = \frac{1}{\rho_{\beta^+} \sigma_d} = \frac{1}{3.20 \times 10^8 \times 215 \times 10^{-24}} = 3.13 \times 10^{15} \text{ cm} \quad 39$$

Consequently these scattering collision and energy changes may be regarded as having a perturbing effect on the single positron behavior in electromagnetic fields.

F. Electric Field

The cloud of positrons will generate an electric field, which must satisfy the following Maxwell equation

$$\vec{\nabla} \cdot \vec{E} = 4\pi\rho_{\beta^+} \quad 40$$

Provided that the radius of the torus is much larger than the radius of the generating circle, we may simplify the geometry of our device assuming a cylindrical shape. Consequently the divergence of \vec{E} in cylindrical coordinates:

$$\vec{\nabla} \cdot \vec{E} = \frac{1}{r} \frac{\partial}{\partial r}(rE_r) + \frac{1}{r} \frac{\partial E_\phi}{\partial \phi} + \frac{\partial E_z}{\partial z} = 4\pi\rho_{\beta^+} \quad 41$$

Because of symmetry: $\frac{\partial E_\phi}{\partial \phi} = 0$, $\frac{\partial E_z}{\partial z} = 0$

therefore

$$\frac{1}{r} = \frac{d}{dr}(rE_r) = 4\pi\rho_{\beta^+}$$

$$E_r = 2\pi\rho_{\beta^+}r + \frac{C}{r} \quad 42$$

B.C.: for $r=0$, $E_r = 0$, consequently $C = 0$.

Finally the radial electric field

$$E_r = 2\pi\rho_{\beta^+}r \quad 43$$

The values of E_r vary from $E_r = 0$ for $r = 0$ to E_{rmax} for $r = 2.5$ cm

$$E_{rmax} = 2\pi \times 3.20 \times 10^8 \frac{\beta^+}{\text{cm}^3} \times \frac{4.8 \times 10^{-10} \text{ statcoul}}{\text{cm}^2} \times 2.5 \text{ cm} =$$

$$= 2.42 \text{ statcoul/cm}^2$$

$$E_{rmax} = 300 \times 2.42 = 726 \text{ Volt/cm}$$

44

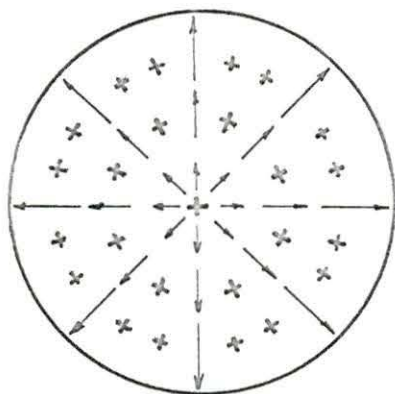

Figure 3. Magnetic and electric field configuration within a section of the torus

G. Pressure

The cloud of positrons, treated as an ideal gas give rise to a pressure which is equivalent to nkT , where n is the total number of positrons per cubic centimeter. In this case

$$n = \rho_{\beta^+} = 3.20 \times 10^8$$

$$P = nkT = 3.2 \times 10^8 \times \frac{2}{3} \times 1.6 \times 10^{-9} =$$

$$= 37.6 \text{ ergs/cm}^3$$

45

where 1.6×10^{-9} is the factor converting kilo-electron volt into ergs.

In a toroidal magnetic field configuration the product of the magnetic field strength times the radius of the force line is a constant

$$BR = \text{constant} \quad 46$$

Therefore the magnetic field strength at the outside will be

$$B_{\text{omin}} = \frac{BR}{R_{\text{out}}} = \frac{1000 \times 25}{27.5} = 910 \text{ gauss} \quad 47$$

Since the radial electrostatic field will give rise to a pressure gradient directed outwards, the net electrical and magnetic pressure at the outside is

$$\frac{B_0^2}{8\pi} - \frac{E_{r\text{max}}^2}{8\pi} = \frac{910^2}{8\pi} - \frac{2.42^2}{8\pi} \quad 48$$

$$\sim \frac{910^2}{8\pi} = 3.29 \times 10^4 \text{ ergs/cm}^3$$

$$\text{Consequently } P \ll \frac{B_0^2}{8\pi} \quad 49$$

or the cloud of positrons can be confined by an external magnetic field of strength B_0 . The leakage of positrons to the walls, by diffusion, will be so small as to permit the ignoring of leakage as a positron loss mechanism in comparison with the loss by annihilation.

H. Drift Velocity

It has been mentioned earlier that in a magnetic field a charged particle gyrates around the field lines; the center of gyration at any instant is called the guiding center of the particle. As the gyrating particle moves along a line of force in a uniform field, it will follow a helical path, but its guiding center will remain on the field line. However, if there is an electric field, a drift motion, which can be expressed as motion of the guiding center, will be superimposed on the normal helical path of the charged particle.

The drift velocity expression can be found in Glasstone and Lovberg (8) as

$$v_d = c \frac{E}{B} \quad 50$$

for the case in which the electric field is perpendicular to the magnetic field. The direction of v_d is perpendicular to both fields. Upon substitution in 50

$$v_d = 3 \times 10^{10} \frac{2.42}{1000} = 7.26 \times 10^7 \text{ cmsec}^{-1} \quad 51$$

Since the direction of this drift velocity is perpendicular to both fields, the superimposed motion will drive positrons along a certain circumference centered in the center of the generating circle of the torus.

Another cause of particle drift can proceed from the toroidal magnetic field shape.

The magnetic field in a torus is both curved and non-uniform and as a result the cloud of positrons would tend to drift vertically (assuming the torus to lie in a horizontal plane). Let u_d be this velocity.

The total drift velocity due to this effect, is the sum of that due to inhomogeneity of the magnetic field and that due to the curvature of the lines of force.

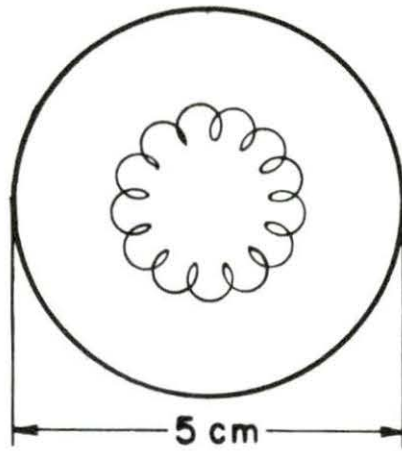

Figure 4. Tangential drift of center of gyration

From Glasstone and Lovberg (8)

$$u_d = \frac{c(W_{\perp} + 2W_{\parallel})}{eBR}$$

52

where $W_{\perp} + W_{\parallel} = W =$ total kinetic energy of the particle,
 R is the radius of the torus.

Since $W_{\perp} + W_{\parallel} = W$, the maximum value of $W_{\perp} + 2W_{\parallel}$ will be $2W$. Upon substituting this value in 52

$$u_{d_{\max}} = \frac{2c_{-W}}{eBR} = \frac{2 \times 3 \times 10^{10} \times 1.602 \times 10^{-6} \text{ erg/MeV}}{4.803 \times 10^{-10} \times 1000 \times 25} \times 0.11 =$$

$$u_{d_{\max}} = 0.0865 \times 10^{10} \text{ cm/sec}$$

This drift velocity in the vertical plane would drive the positrons en masse into the top or the bottom of the torus (depending on the direction of B) after an average time of around 2.5×10^{-9} sec. If this effect were not remediable it would prevent any worthwhile accumulation of positrons in the torus. However, it is not, and the remedial measures will be discussed in the next chapter.

I. Radiation Losses

If one assumes that there are not impurities for the present, energy will inevitably be lost in the form of bremsstrahlung, that is, continuous radiation emitted by charged particles as a result of deflection by the Coulomb fields of other charged particles.

The positron-positron bremsstrahlung in the nonrelativistic limit, as is stated by Post (10) for the analogous case of electron-electron bremsstrahlung, would give rise to no bremsstrahlung losses. In this case, as it already has been stated, the relativistic effects are marginal, but the bremsstrahlung losses should be calculated to see if they are of any importance.

Although this process has been calculated to various degrees of approximation by several investigators, not all the

all the calculations agree, and few papers on the subject have been published. Stickforth, as quoted by Post, had performed detailed calculations on this effect. His results may be simply stated as a ratio of electron-electron to the ordinary electron-ion bremsstrahlung for $Z = 1$. For an energy around 100 kev, as in our case, the ratio should be 0.34. From Glasstone and Lovberg (8) we get for a hypothetical positron-ion interaction

$$P_{br} = 5.35 \times 10^{-24} \times \rho_{\beta^+}^2 (W)^{\frac{1}{2}} = 5.35 \times 10^{-24} \times (3.20 \times 10^8)^2 \times 110^{\frac{1}{2}} = 5.75 \times 10^{-6} \text{ ergs/cm}^3 \text{ sec} \quad 54$$

The positron-positron interaction value will be:

$$P_{br\beta^+} = 0.34 \times 5.75 \times 10^{-6} = 1.95 \times 10^{-6} \text{ ergs/cm}^3 \text{ sec}$$

$$P_{br\beta^+} = \frac{1.95 \times 10^{-6}}{3.20 \times 10^8} = 6.1 \times 10^{-15} \text{ ergsec}^{-1}/\beta^+ \quad 55$$

The corresponding decrease of velocity at the end of the first second

$$u' = \frac{6.1 \times 10^{-15}}{9.1 \times 10^{-28} \times 1.71 \times 10^{10}} = 3.92 \times 10^2 \text{ cm/sec}^2 \quad 56$$

Since this decrease of velocity is pretty much smaller than the drift velocity, as calculated in 53, its influence is insignificant.

In addition to the loss of energy as bremsstrahlung, there is another possible way in which energy may be radiated

from a positron cloud. As we already know the positrons spiral about the lines of force at definite frequencies. The centripetal acceleration of these charged gyrating particles is accompanied by the emission of cyclotron radiation.

The classical expression for the rate P_{cy} at which energy is irradiated by an accelerated positron is

$$P_{cy} = \frac{2e^2}{3c^3} a^2 \quad 57$$

where a is the acceleration of the positron.

Assuming the average value of the velocity, the acceleration of the positron in its motion of gyration will be

$$a = \frac{\bar{v}^2}{r_g} = \frac{(1.71 \times 10^{10})^2}{1} = 2.92 \times 10^{20} \text{ cm/sec} \quad 58$$

substituting in 57

$$P_{cy} = \frac{2 \times (4.80 \times 10^{-10})^2}{3 \times (3 \times 10^{10})^3} \times 2.92 \times 10^{20} = 1.66 \times 10^{-30} \text{ ergsec}^{-1}/\beta^+$$

which is insignificant compared with the bremsstrahlung energy loss.

No consideration need be taken for the black-body radiation, because of the very low particle densities. A system of this type is optically "thin" and transparent to essentially all the bremsstrahlung from the cloud of positrons; it is a poor absorber, and hence also a poor emitter, of this radiation. Therefore a radiation equilibrium does not prevail in the system and black body losses may be ignored.

IV. DISCUSSION AND CONCLUSIONS

A. Discussion

From the previous chapter it can be concluded that a positron storage ring using a radioactive source is feasible, provided that the bulk drift to the wall can be prevented. An examination of the drift velocity equation 52 shows us that the drift to the wall can be diminished by:

1. Reducing the velocity of the positrons, for ex., by means of a thin aluminum foil outside and around the source.
2. Increasing the value of the radius R of the torus.
3. Increasing the strength of the magnetic field. This way, however, will be less desirable than the others, because by increasing the magnetic field strength the radius of gyration will also be diminished according to equation 28, and in turn the probability of collision between positrons and the sample will be increased.

Even if the reduction of the drift velocity would be by a factor of about 10^3 , the positrons would still be driven into the wall after an average time of about 2.5×10^{-6} sec.

This can be remedied, however, by either of two changes in the design of the container. The first one of these is to impose a rotational transform on the magnetic field, either by twisting the torus into a figure eight shape, or if the

lines of force are twisted by means of a helical magnetic field superimposed on the confining field, in a planar torus. In either case the positrons will drift in opposite directions in opposite sections of the torus.

The second method is to scallop the torus. This involves the modification of the simple toroidal device by a series of short alternating curved pieces, called scallops, in which the magnetic field lines have opposite but equal curvature, as shown in Figure 5. Since the particle drift in alternate scallops will be in opposite directions, the resultant drift will be small.

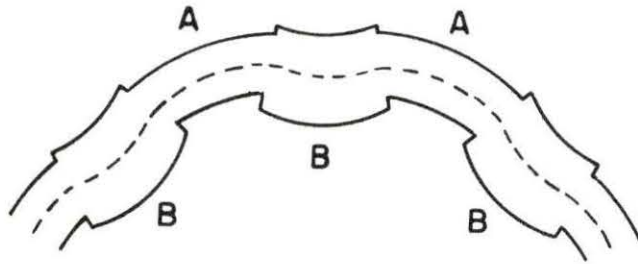

Figure 5. A schematic illustration of a scalloped section of toroidal device

As Glasstone and Lovberg (8) advise, in order to obtain a net bending of the lines of force, that is, for the overall

curvature of the scalloped section to be the same as that of the section it replaces, the scallops A, which curve in the required direction, must be longer than those marked B, having equal curvature in the opposite direction. However, to equalize the particle drift in adjacent scallops, the magnetic field strength in the shorter sections must be decreased relative to those in the longer sections, in proportion to their lengths, assuming the radii of curvatures to be equal. This can be achieved by making the shorter scallops wider than the longer ones, as indicated in Figure 5.

Therefore, if the scalloping or the rotational transform of the toroidal device were one hundred per cent effective the foregoing shows that we could achieve a positron density of the order of 10^8 or 10^9 per cm^3 .

Even if we did not use the above modifications, we still could get an accumulation of positrons in the device because the source gives off positrons of all energies up to the upper limit. The high energy positrons are driven quickly into the wall, but the low energy ones slowly. Consequently the torus will selectively store the low energy positrons and a certain equilibrium concentration of these will be reached. Because the emission rate of the low energy positrons is less than the total activity of the source, the equilibrium concentration of the low energy positrons would be less than what it would be if positrons of all energies up to the upper limit could be retained within the torus.

If however the energy of all the positrons can be reduced without substantial losses by annihilation (by covering source with thin foil), then the equilibrium concentration of low energy positrons within the torus should be substantially the same as for high energy positrons in the absence of bulk drift.

B. Recommendations for Further Study

It remains to calculate the equilibrium concentration of positrons within definite limits of energy.

Secondly, in the case of the scalloped or rotationally transformed device, the effectiveness of the scalloping or rotational transform must be accurately investigated in order to see how close we can get to the maximum theoretical value of positron density, about $10^9/\text{cm}^3$.

V. BIBLIOGRAPHY

1. O'Neill, Gerard K. Particle storage rings. *Scientific American* 215, No. 5: 107. 1966.
2. Goujou, J. and Sittel, R. Les anneaux de stockage. *Science Progres. La Nature* 3371: 97. 1966.
3. Amman, F. Adone, The Frascati 1.5 GeV electron-positron storage ring. *Laboratori Nucleare di Frascati*. August, 1965.
4. Friedlander, G., Kenedy, J., and Miller, J. Nuclear and radiochemistry. John Wiley and Sons, Inc., New York, N.Y. 1966.
5. Nuclear data sheets. Nuclear Data Group, National Academy of Science--National Research Council, Washington, D.C. 1964.
6. Price, William J. Nuclear radiation detection. McGraw-Hill Book Co., New York, N.Y. 1958.
7. Evans, R. D. The atomic nucleus. McGraw-Hill Book Co., New York, N.Y. 1955.
8. Glasstone, S. and Lovberg, R. Controlling thermonuclear reactions. D. Van Nostrand Co., Inc., New York, N.Y. 1960.
9. Segre, Emilio. Nuclei and particles. W. A. Benjamin, New York, N.Y. 1965.
10. Post, R. F. High-temperature plasma research and controlled fusion. *Ann. Rev. Nuc. Sci.* 9: 379. 1959.